

dimensions in mm

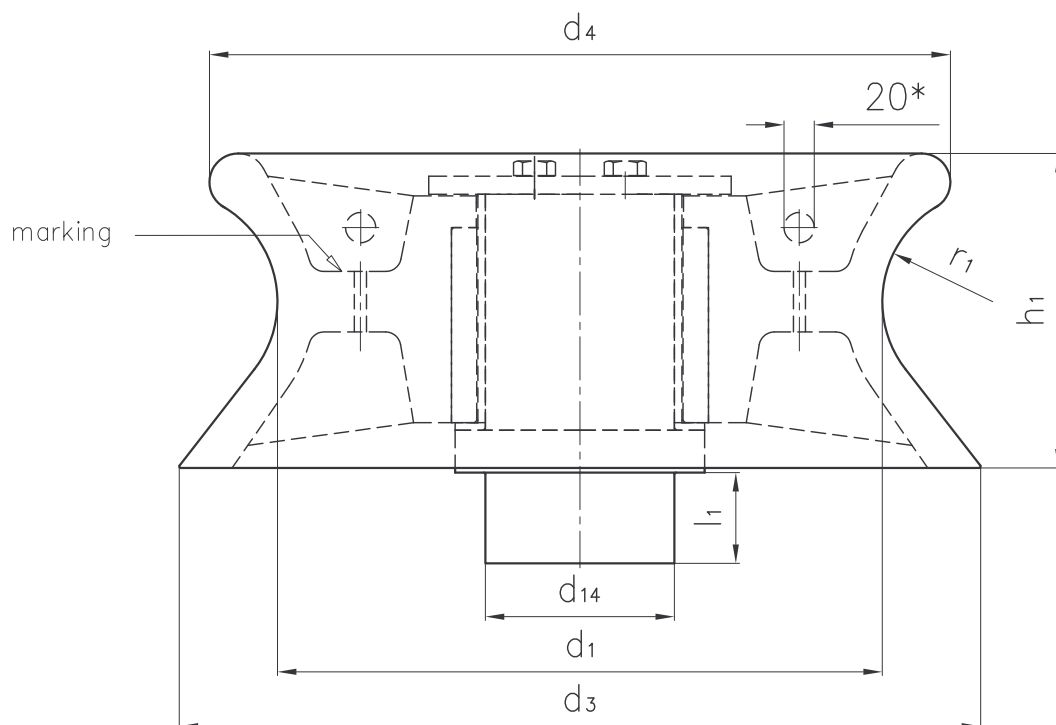

description of a warping roller of rated size 8

WARPING ROLLER DIN 81906 – 8

rated size	nom. towing pull (kN)	d_1	d_3	d_4	d_{14}	h_1	l_1	r_1	weight kg/piece ~
1	10	160	210	195	60	80	50	25	12
2	20	200	265	245	70	102	50	32	18
3	32	250	330	300	85	126	50	42	33
5	50	320	420	390	106	160	50	55	68
8	80	400	530	490	125	208	60	73	136
12	125	450	610	560	160	256	85	95	225
20	200	500	640	620	190	278	100	111	336
32	320	560	780	740	230	348	150	125	580

gepr.:

H. A. Schröder
GmbH & Co. KG
Schiffdorf-Wehden

WARPING ROLLER
LR 83/A4/02.1E

M. 1:5

Dat. 23.04.2002

0081 906

Dimensions in mm

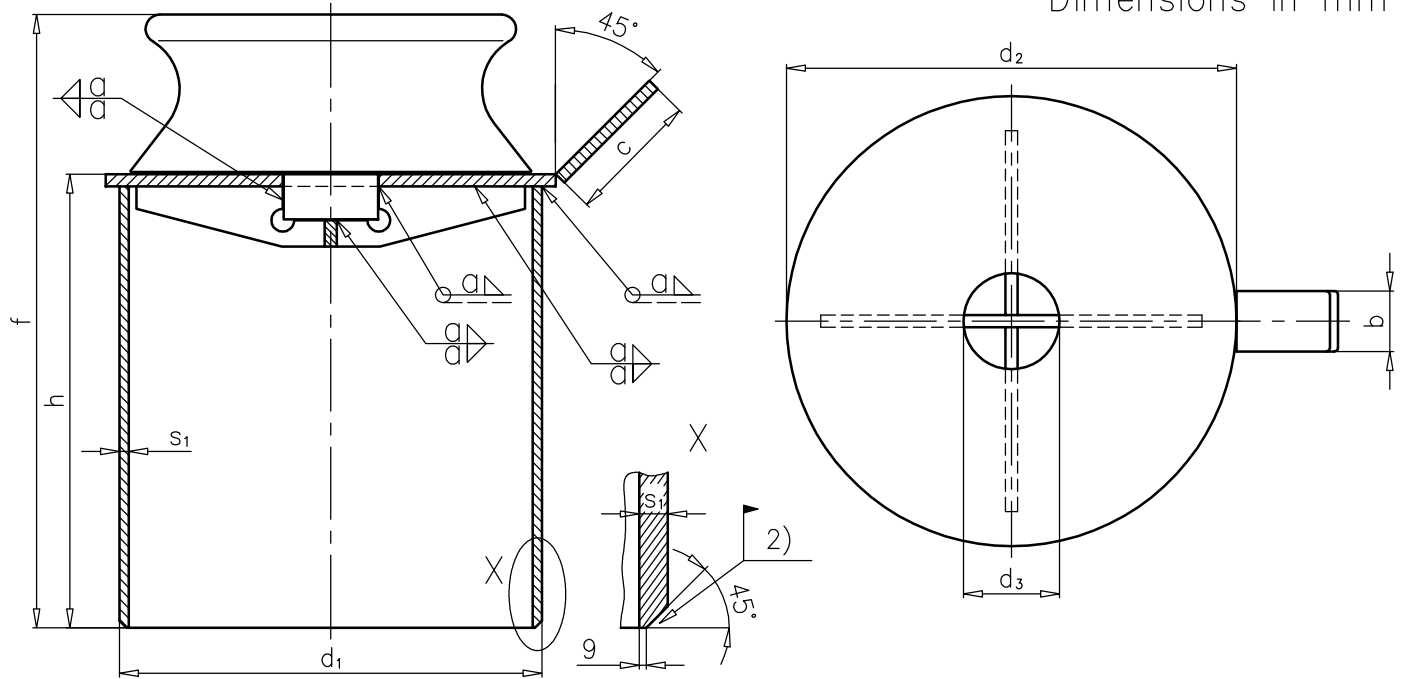

Description of a pedestal fair lead with base type A of size 8 and h=600 mm height of base :

Pedestal fair lead DIN 81907 – A 8 – 600

Rated size	For cable tension of kN	Height of base h	Welding seam a	b	c	Pipe d ₁ x s ₁	d ₂	d ₃ ±1	f	Weight kg/piece ~
1	10	200	9	60	135	219,1x12,5	255	62	282	31
		400							482	44
		600							682	57
		800							882	70
2	20	200	9	60	135	273x12,5	310	72	305	43
		400							505	59
		600							705	75
		800							905	91
3	30	200	9	60	135	355,6x12,5	395	87	329	68
		400							529	89
		600							729	111
		800							929	132
5	50	200	9	60	135	457x12,5	495	108	363	117
		400							563	144
		600							763	172
		800							963	199
8	80	200	9	80	175	559x12,5	595	127	411	209
		400							611	242
		600							811	276
		800							1011	310
12	120	200	10	80	175	660x14,2	705	162	459	325
		400							659	370
		600							859	415
		800							1059	460
20	200	200	12	100	220	660x17,5	705	192	483	460
		400							683	516
		600							883	571
32	320	200	12	100	220	813x16	865	232	553	748
		400							753	810
		600							953	873

gepr.:

H. A. Schröder
 GmbH & Co. KG
 Schiffdorf-Wehden

Pedestal fair lead
 with base, type A

M. Dat. 08.05.2002

LR 37/A4/01E

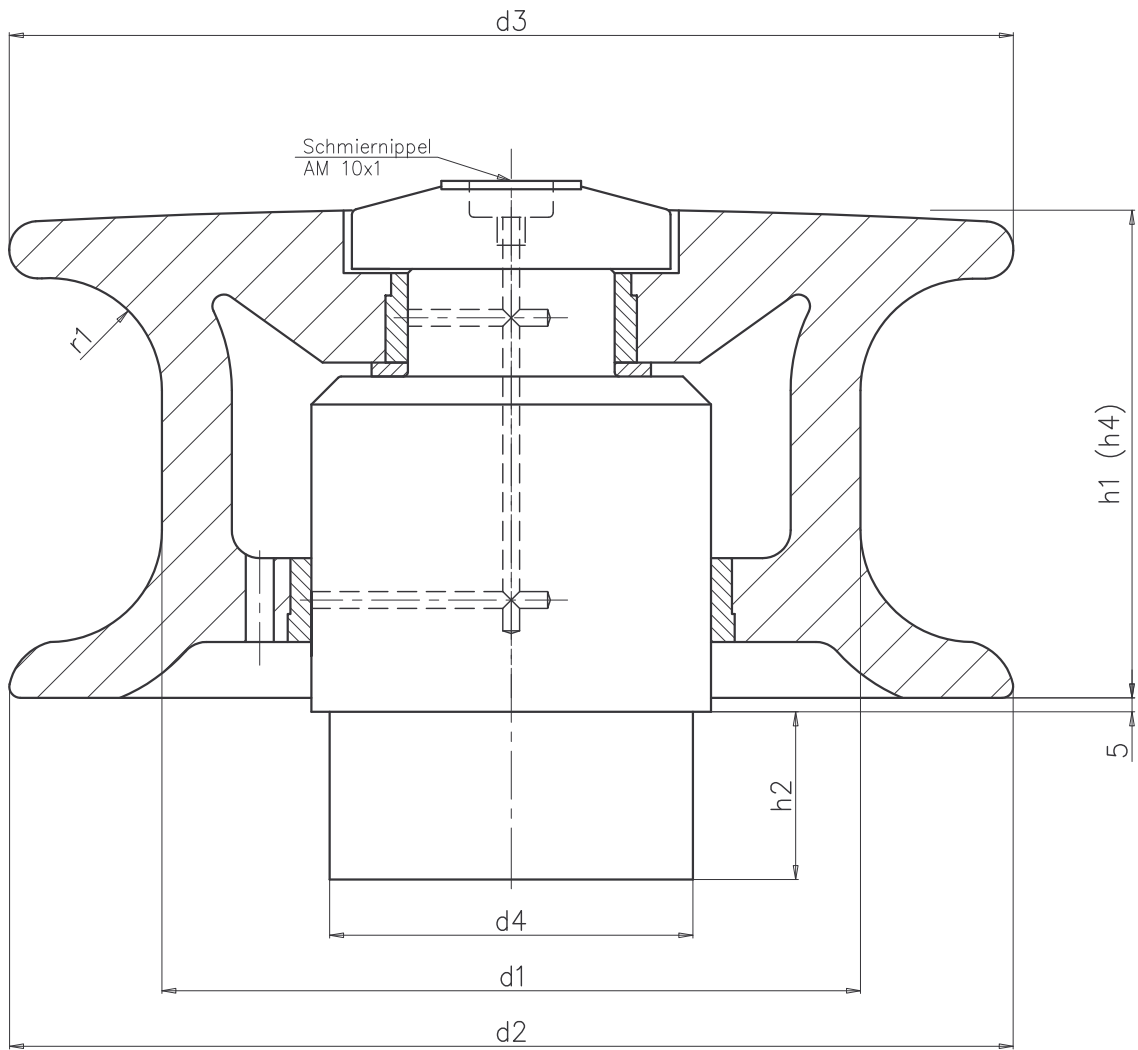

Seil- zug- kraft	d1	d2	d3	d4	h1	h2	Alter- nativ h4
3t	150	240	240	70	145	50	
5t	200	295	270	105	156	50	
8t	250	360	340	125	175	60	
12t	300	410	390	160	185	60	
16t	350	500	460	180	225	80	
20t	400	570	530	195	250	100	300

H. A. Schröder GmbH & Co. KG Schiffdorf-Wehden						M. ./.	
				2003	Datum	Name	
				Bearb	12.09	Stü	
				Gepr			
				Norm			
				Verholrolle Typ LE			
				LR 41/A4/01			
Zust	Änderung	Datum	Nam				